

Nina Campbell

MARGOT 3 DRAWER CHEST



A new addition to our growing Margot Collection the 3 drawer chest, elegant curved lines, hand painted and finished in a beautiful Mineral white.

PRODUCT CODE SKU 440489

DIMENSIONS

Width: 97cm/ 38"

Height: 76cm/ 30"

Depth: 46cm/ 18"

LEATHER INLAY

Leather colour can be customised in any leather of your choice

COL required:

FINISHES

All finishes can be viewed [here](#)

DELIVERY

8-10 weeks

Made in the UK

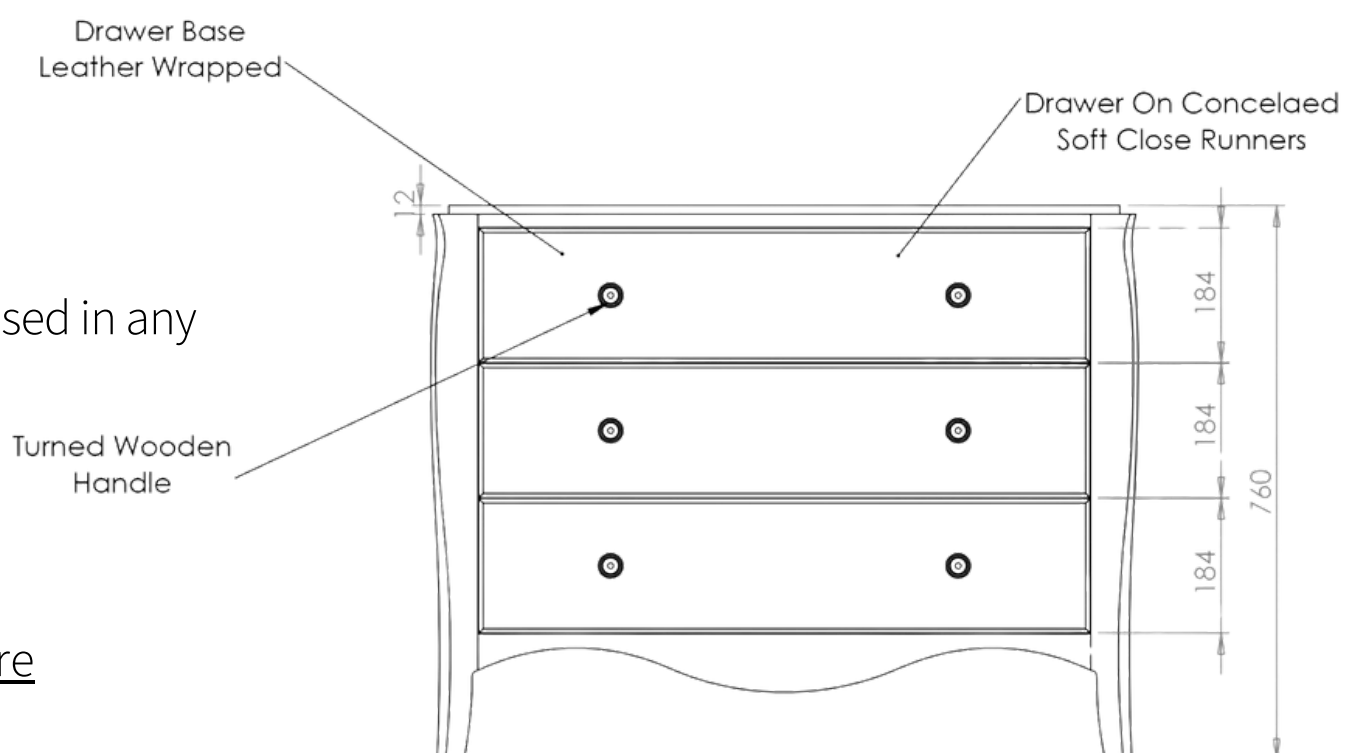

IMAGE DIMENSIONS IN CM

For more information please email furniture@ninacampbell.com

ninacampbell.com